

Multifrequency PLL Clock Synthesizer

Applications

- Set-top boxes
- MPEG video clock source

General Description

The TLSI T98000 is a single-chip, integrated multiple Phase Locked Loop (PLL) clock synthesizer. The device uses an analog Phase Locked Loop (PLL) to accept a 27 MHz crystal input to produce multiple outputs. Selection pins are used to provide various outputs.

Features

- 24.576 MHz for Firewire IEEE1394 or video digitizer
- 24.576 MHz / 28.224 MHz for software or hardware modem
- 27 MHz buffered output clock
- 6.000MHz buffered output clock
- 18.432 MHz for audio processor
- 2kHz standby clock
- Zero ppm synthesis error in all clocks (except the 2 kHz standby clock)
- 5V tolerant inputs
- 20-pin, 150 mil SSOP (QSOP)

Figure 1. Functional Block Diagram

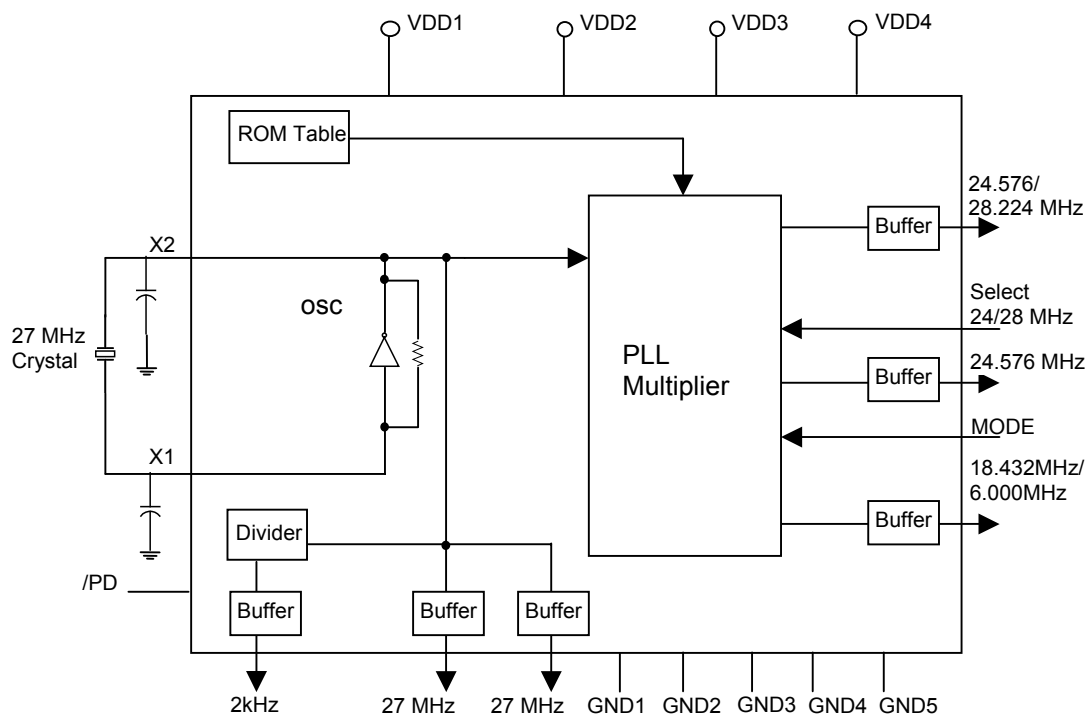

Figure 2. Pin Configuration (Top View)

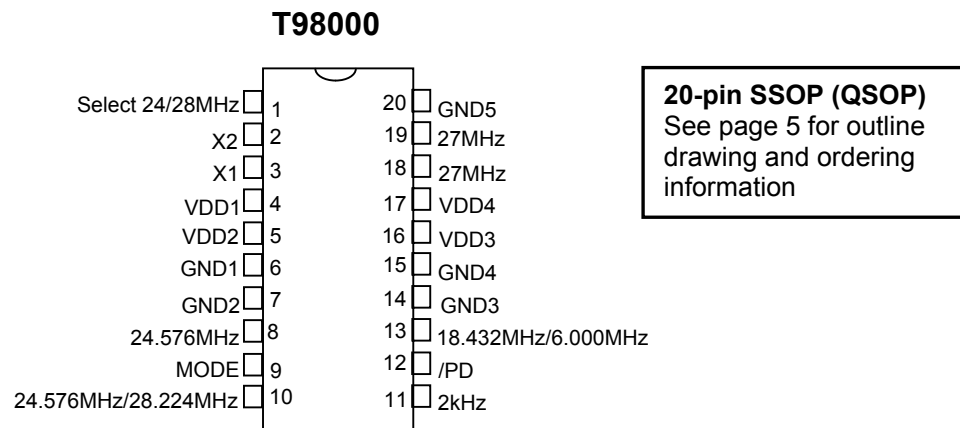

Table 1. Pin Descriptions

Name	Pin #	Type	Description
Select 24/28 MHz	1	I(PU)	Select 24.576 MHz or 28.224 MHz output
X2	2	O	Crystal connection. Connect to a 27 MHz crystal
X1	3	I	Crystal connection. Connect to a 27 MHz crystal
VDD1	4	P	Connect to 3.3V
VDD2	5	P	Connect to VDD
GND1	6	P	Connect to ground
GND2	7	P	Connect to ground
24.576 MHz	8	O	Clock output, 24.576 MHz
MODE	9	I(PU)	Mode control. See Table 2
24.576 MHz/ 28.224MHz	10	O	Clock output, 24.576 MHz or 28.224 MHz
2 kHz	11	O	Clock output, 2 kHz
/PD ⁽¹⁾	12	I(PU)	Powerdown control. When LOW, all clocks are disabled except 2kHz standby clock
18.432MHz/6.000MHz	13	O	Clock output, 18.432 MHz or 6.000 MHz
GND3	14	P	Connect to ground
GND4	15	P	Connect to ground
VDD3	16	P	Connect to VDD
VDD4	17	P	Connect to VDD
27 MHz	18,19	O	27 MHz buffered clock outputs
GND5	20	P	Connect to ground

Legend: I = Input
 O = Output
 P = Power supply connection
 I(PU) = Input with a 250k ohm pull up

Note (1). All disabled clock outputs are tristated (high impedance).

Table 2. Mode Control and Frequency Selection Table (/PD = HIGH) ^(1,2)

Control ⁽³⁾		Outputs	
Pin 9 Mode	Pin 1 (Select 24/28MHz)	Pin 10 (24.576 MHz / 28.224 MHz)	Pin 13 (18.43 MHz / 6 MHz)
0	0	High Impedance	18.432 MHz
0	1		
1	0	24.576 MHz	6 MHz
1	1	28.224 MHz	

Notes: 1. 27MHz (Pins 18 &19) and 24.576 MHz (Pin 8) are active, unless /PD = LOW
 2. 2 kHz standby clock is always active, independent of /PD logic state
 3. 0 = Low, 1 = HIGH

Table 3. Recommended Crystal Specifications

Frequency accuracy is directly proportional to the capacitive load (CL) of the crystal.

Parameter	Definition	Min	Typ	Max	Units
Frequency at CL, FL	Defines the series resonant frequency at CL		27.000		MHz
Total accuracy: includes initial accuracy @ 25°C, aging, and temperature drift (25°C to 70°C)	Maximum deviation from nominal frequency @ 25°C, taking in to account aging, and temperature drift			40	ppm
Load Capacitance CL	Capacitive load for nominal frequency FL		20		pf
C1	Motional capacitance of the crystal			TBD	pf
C0	Shunt capacitance of the crystal			7	pf
ESR	Equivalent Series Resistance of the crystal			40	ohms

Table 4. Absolute Maximum Ratings

Parameter	Conditions	Min	Typ	Max	Units
Supply voltage, V _{DD}	Referenced to GND			7	V
Inputs and Clock Outputs	Referenced to GND	-0.5		V _{DD} +0.5	V
Soldering Temperature	Max of 10 seconds			+260	°C
Storage temperature		-65		+150	°C

Stresses above those listed under Absolute Maximum Ratings may cause permanent damage to the device. These ratings are stress specifications only and correct functional operation of the device at these or any other conditions above those listed in the operational sections of the specifications is not implied. Exposure to absolute maximum rating conditions for extended periods may affect product reliability.

Table 5. Operating Conditions

Parameter	Conditions	Min	Typ	Max	Units
Power Supply Voltage, V _{DD}		+3.0	+3.3	+3.6	V
Input High Voltage, V _{IH}		+2.0		V _{DD}	V
Input Low Voltage, V _{IL}				+0.8	V
Operating Temperature, T _A		0	+25	+70	°C

Table 6. DC Electrical CharacteristicsT_A = 0°C to +70°C, V_{DD} = +3.135 V to +3.465 V

Parameter	Symbol	Min	Typ	Max	Units
Output voltage high I _{OH} = -8 mA	VOH	+2.7			V
Output voltage low I _{OL} = 8 mA	VOL			+0.4	V
Maximum input capacitance (X1,X2)	Cin			3	pF
Power consumption (operating)	I _{dd1}		50		mA
Power consumption (powerdown)	I _{dd2}		TBD		mA

Note:

1. Typical values are at V_{DD} = 3.3V and 25°C

Table 7. Phase Noise Characteristics (Crystal phase noise must be less than -130 dBc/Hz @ 10kHz)

Parameter	Symbol	Min	Typ	Max	Units
27 MHz		-120			dBc/Hz @ 10 kHz
24.576 MHz		-100			dBc/Hz @ 10 kHz
24.576/28.224 MHz		-100			dBc/Hz @ 10 kHz
18.432/6.000 MHz		-100			dBc/Hz @ 10 kHz

Table 8. Output Accuracies (Excluding crystal accuracy)

Parameter	Symbol	Min	Typ	Max	Units
24.576/28.224 MHz				0	ppm
2kHz				50	%
18.432/6.000 MHz				0	ppm
27 MHz				0	ppm

Table 9. AC CharacteristicsAll @Cload = 20 pF, V_{DD} = 3.0V to 3.6V

Parameter	Symbol	Min	Typ	Max	Units
Duty Cycle @ V _{DD} /2	δ			45/55	%
Rise time (measured between 0.8V and 2.0V)	Tr	1		2.5	ns
Fall time (measured between 0.8V and 2.0V)	Tf	1		2.5	ns
PLL lock time	Tlock				ms
Time to clock outputs after VDD is available	Tst			50	ms

Figure 3. Package Outline Drawing (20-pin SSOP/QSOP)

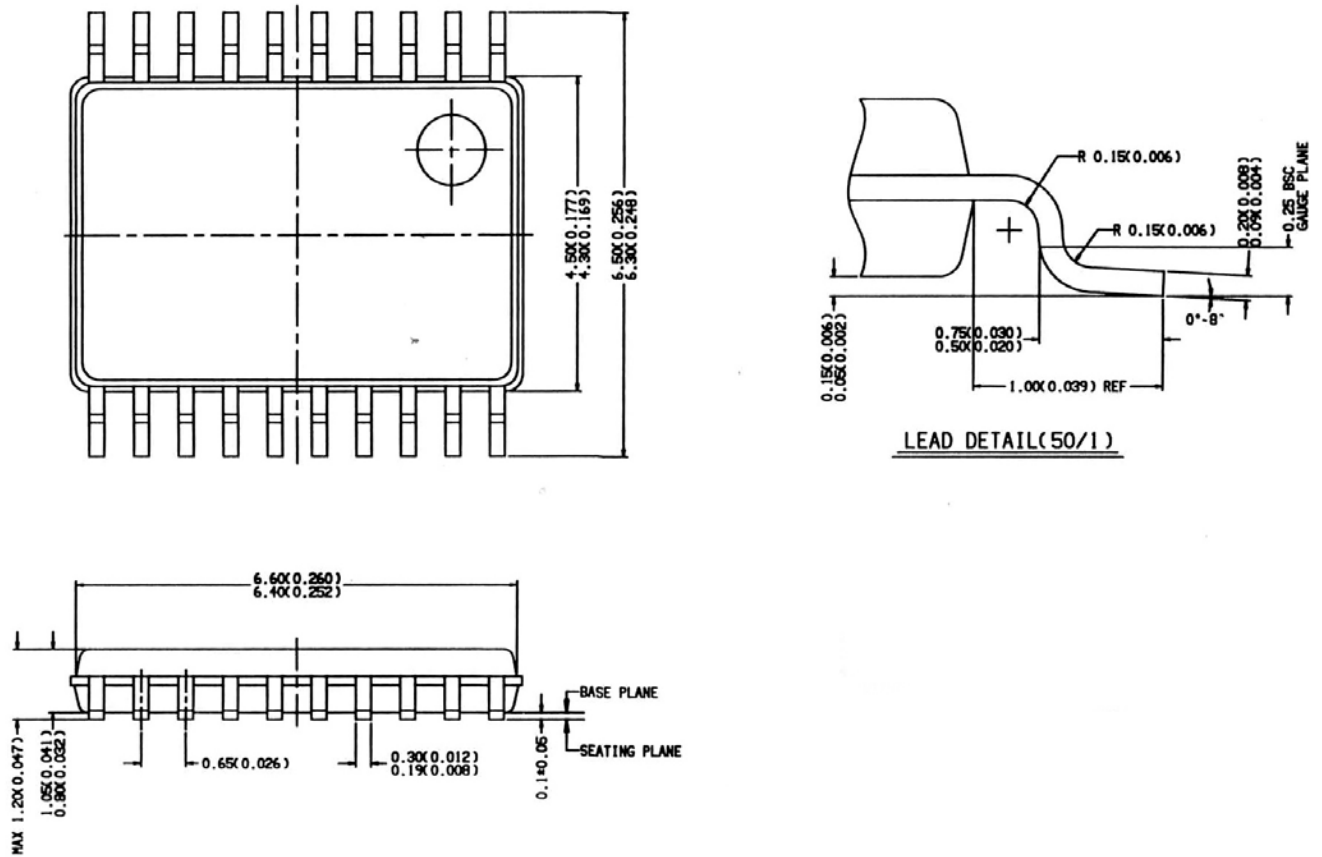

Table 10. Ordering Information

Part Number	Marking	Shipping/Packaging	No. of Pins	Package	Temperature
T98000-SS20	T98000	Tubes	20	TSSOP	0°C to +70°C
T98000-SS20-TNR	T98000	Tape & Reel	20	TSSOP	0°C to +70°C
T98000-DIE	N/A	Die in Waffle Pack	20	N/A	0°C to +70°C